

When ordering parts from this catalog please furnish the page number, code number and machine serial number.

CODE NO.	DESCRIPTION	QTY	CODE NO.	DESCRIPTION	QTY
2-1	Follower, Cam	8	2-22	Shaft, Swing	1
2-2	Washer	8	2-23	Stud, Tensioner	1
2-3	Gear, Change	2	2-24	Sprocket, Idler	1
2-4	End Plate, Carriage, O.S.	1	2-25	Screw, Cap, Socket Hd.	4
2-5	Nut, Hex.	8	2-26	Bushing	1
2-6	Bushing	2	2-27	Guard, Chain	1
2-7	Sprocket, Stationary	1	2-28	Block, Trail Support	2
2-8	Chain, Roller	59	2-29	Bolt, Hex. Hd.	6
2-9	Wheel, Worm, Swing	1	2-30	Washer, Lock	6
2-10	Cross-Tie, Carriage	1	2-31	Screw, Flat Hd.	1
2-11	Shaft, Paralleling	1	2-32	Washer	1
2-12	Pin, Dowel	2	2-33	Nut, Hex.	1
2-13	End Plate, Carriage, D.S.	1	2-34	Washer, Lock	1
2-14	Screw, Cap, Socket Hd.	6	2-35	Washer, Flat	1
2-15	Pin, Dowel	2	2-36	Axle	1
2-16	Cover, Pinion	2	2-37	Tube, Trail Support	1
2-17	Screw, Button Hd.	4	2-38	Screw, Cap, Socket Hd.	10
2-18	Bolt, Hex. Hd.	6	2-39	Lip, Trail Support	1
2-19	Washer, Lock	10	2-40	Sprocket, Axle	1
2-20	Arm, Swing	2	2-41	Screw, Button Hd.	6
2-21	Bushing	4	2-42	Washer, Lock	6

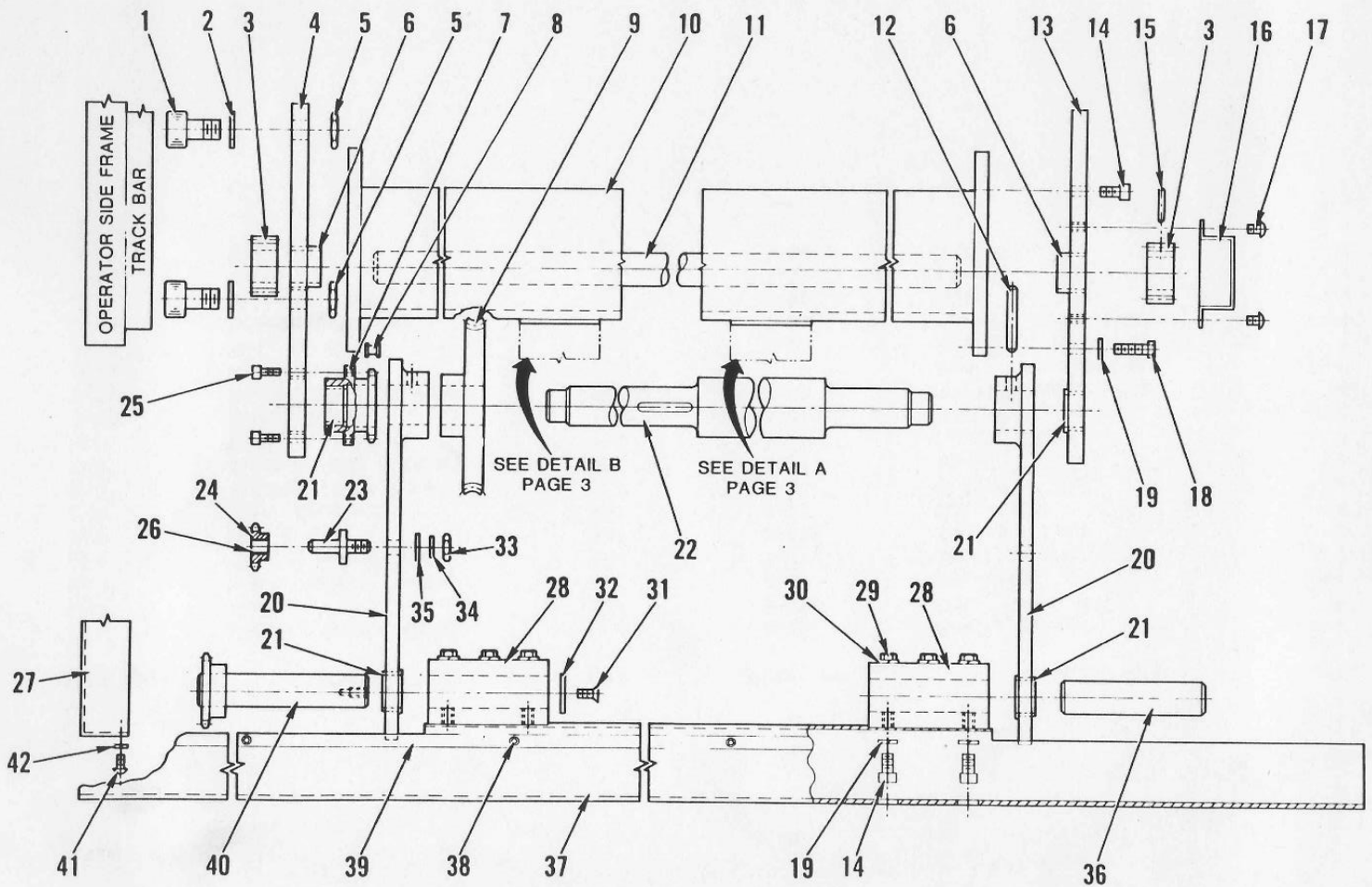

TRAIL SUPPORT ASSEMBLY