

When ordering parts from this catalog please furnish the page number, code number and machine serial number.

CODE NO.	DESCRIPTION	QTY	CODE NO.	DESCRIPTION	QTY
9-1	Filter-Regulator	1	9-11	Switch, PB, Stop	1
9-2	Lubricator	1	9-12	Switch, PB, Feed/Int/Auto	1
9-3	Shaft, Input	Ref	9-13	Switch, PB, Skip Feed On/Off	1
9-4	Target, Proxy Switch	1	9-14	Switch, PB, Blower Motor	1
9-5	Switch, Proximity	1	9-15	Conduit, Elect. (Sealtite)	AR
9-6	Frame, Inner, O.S.	Ref	9-16	Angle, Mtg, Proxy Switch	1
9-7	Brace, Inner Frame	2	9-17	Enclosure	1
9-8	Frame, Inner, D.S.	Ref	9-18	Panel	1
9-9	Foot, Upper Frame	2	9-19	Module, Synch Logic	1
9-10	Enclosure	1	9-20	Solenoid (Air Valve)	1

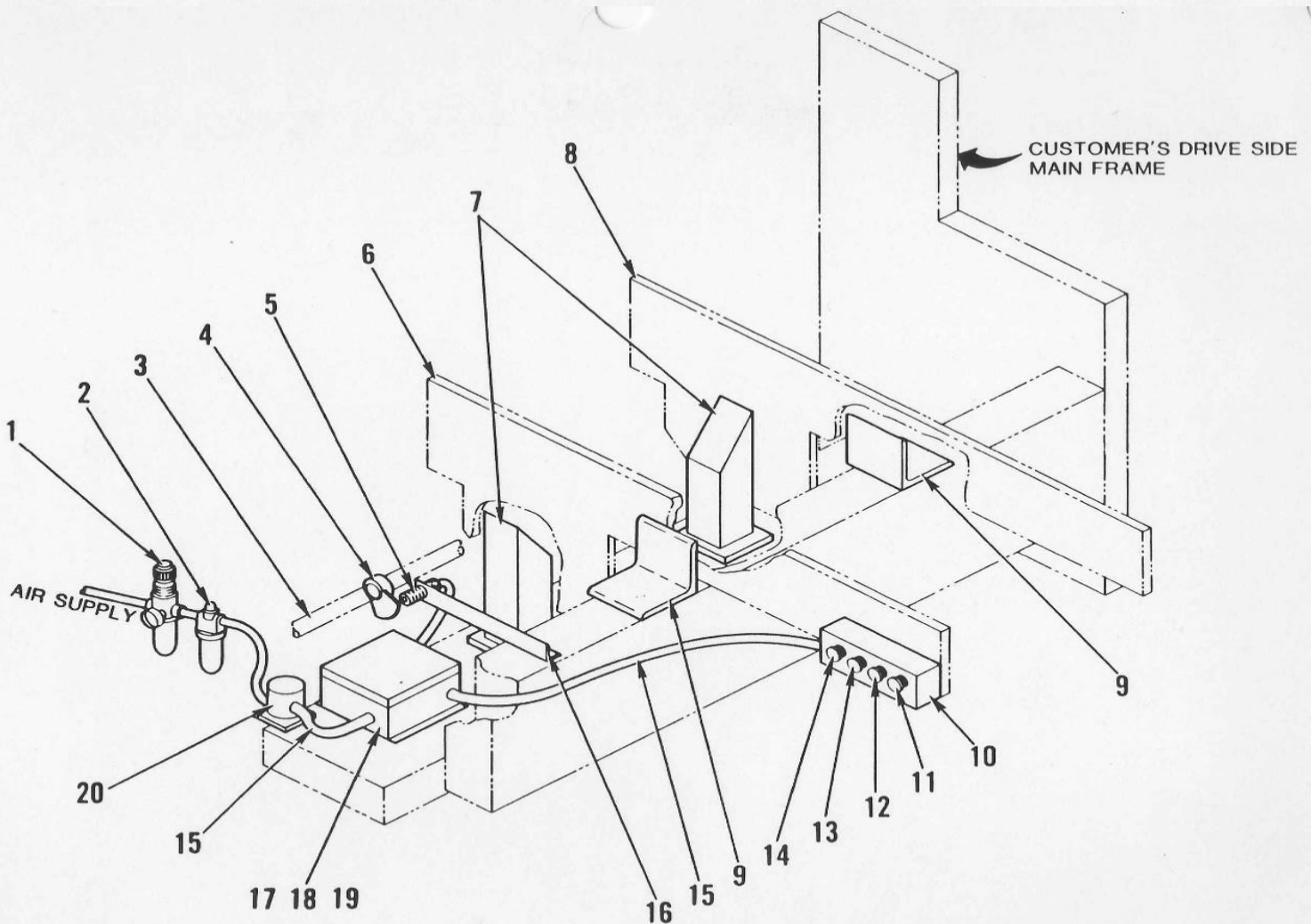

ELECTRICAL & MECHANICAL TIE-INS